



## Motor Drive MPP 2000/200i

The MPP 2000/200i motor drive represents a gadget serving local, remote, central, and manual handling of section disconnectors. It is applied in particular in the area of railway overhead contact lines; however, it is also designated for use in municipal transport overhead contact lines and in the distribution systems too.

The motor drive is supplied in two basic versions – housed in a plastic box or in a metal box. The box can be locked with help of a switchboard lock and it is fixed to the bearing structure with help of four M10 screws. The box contains a drive train together with a connecting block and control elements. The drive train consists of a three-phase (asynchronous) squirrel-cage induction motor with a support condenser; the DC version features a serial collector motor. The rotor revolutions are transmitted by way of a gear box to a motion screw and a nut, which is firmly connected to an extensible quill. The quill terminates with a fork to which the disconnector drawbars are attached. If necessary, the drive can be controlled with help of a in-built local electric control unit with a three-position switch or with help of a hand crank.

### Description

- In-built protection against mechanical overload by way of an adjustable mechanical clutch;
- Motor Drive MPP 2000/200i Up-stroke adjustable by way of end-limit switches;
- Wide options of supply voltages: AC 230 V or DC 230 V, 110 V, 24 V, 12 V;



- Wide options of connection via 3-to-6-core cables, depending on the requirements for local electrical control and remote signaling of the position of the disconnector;
- In-built heating element switched on and off via a thermostat, in order to ensure operability under low temperatures;
- Door fitted with an end-limit switch.

### Technical specifications

- Drawbar momentum: max. 2 300 N;
- Operating speed: 20 mm/s;
- Maximum up-stroke: 200 mm;
- Weight: 35 kgs;
- Operating temperature: -25 deg. Celsius to +55 deg. Celsius;
- Protection provided by enclosure: IP 44;
- Double insulation (only for the plastic box).

### References

- SŽDC Czech Republic
- ŽSR Slovakia
- AS Eesti Raudtee Estonia
- LDz Latvia
- ŽICG Montenegro

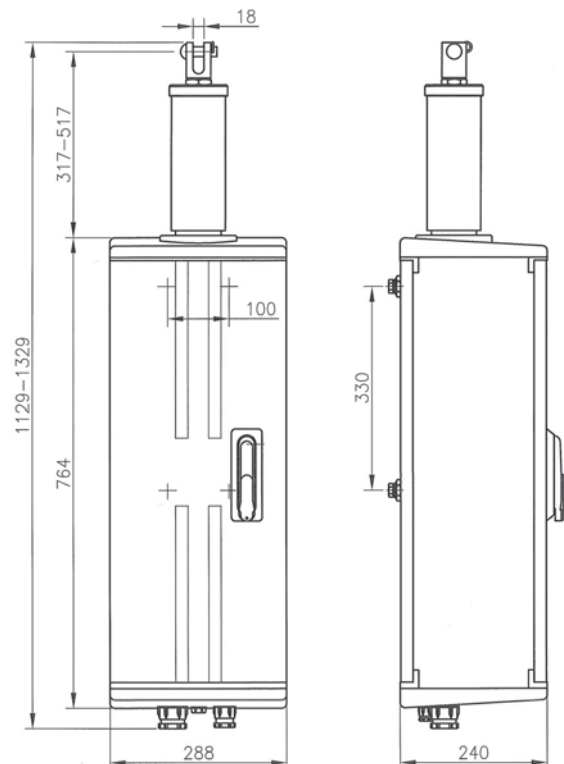

**ELEKTRIZACE ŽELEZNIC PRAHA a. s.**

nám. Hrdinů 1693/4a,  
140 00 Praha 4 Czech Republic

Phone: +420 296 500 101 - Managing Director Secretariate  
+420 296 500 301 - Commercial Dpt.  
+420 296 500 311- Export Dpt.  
e-mail: info@elzel.cz

[www.elzel.cz](http://www.elzel.cz)